

Regulatory Information Report

RPF23095

**Fire resistance test for an air duct passing
through a horizontal separating element –
Internal fire**

Issued to:	Firestop Centre Ltd
Test method:	AS1530.4-2014
Report Date:	30/01/2024
Valid till:	09/08/2028
Test number:	PF23095



Table of Contents

- 1.1 Document revision schedule 3
- 1.2 Signatories 3
- 2. Report Summary..... 4
- 3. General Information 5
 - 3.1 Testing Scope 5
 - 3.2 Contact Details..... 5
 - 3.3 Timeline 6
 - 3.4 Use of the Report..... 6
- 4. Specimen Description..... 7
 - 4.1 Supporting Construction..... 7
 - 4.2 Specimen 1 - Duct..... 7
 - 4.3 Specimen 2: Hatch..... 13
- 5. Additional temperature measurements 16
- 6. Permissible variations to the tested specimen 17



1.1 Document revision schedule

Revision #	Date	Description
1	15/12/2023	Initial issue for Client review
2	19/01/2024	Issued with Client comments
3	25/01/2024	Minor amendments
4	30/01/2024	Minor amendments

1.2 Signatories

Report	Name	Signature	Date
Prepared by:	Alex Kokorin		30/01/2024
Authorised by:	Andrew Bain (Authorized signatory)		30/01/2024



All tests reported herein
have been performed in
accordance with the
laboratory's scope of
accreditation

2. Report Summary

A 800mm x 800mm (W/H) air duct was installed vertically, penetrating through a timber joists floor, with 1 x 16mm FR Plasterboard on the exposed face, 1 x 19mm Structural Chipboard on the unexposed face and 13mm FR Plasterboard was installed around the aperture. The supporting construction aperture was protected using a combination of steel brackets, FR board and acrylic sealant. The duct was protected using 38mm thick FIRESTOP Duct Wrap-38, fixed using steel pins.

Test results – Duct – internal fire

Structural adequacy	No Failure at 66 minutes
Integrity	No Failure at 66 minutes
Insulation	21 minutes
Fire resistance level (FRL)	60/60/15

Test results – Access hatch

Structural adequacy	Not applicable
Integrity	No Failure at 66 minutes
Insulation	60 minutes
Fire resistance level (FRL)	-/60/60

The conditions of the test complied with AS1530.4-2014 requirements.

There were no major observations related to the performance criteria during the test.

3. General Information

3.1 Testing Scope

Applicable Standards:

AS 1530.4-2014 Section 9 Air ducts – Internal fire

AS 1530.4-2014 Section 10 Service penetrations and control joints

Departures from Testing Method:

No departures from the testing method.

Conditions of the test complied with AS1530.4-2014 requirements.

3.2 Contact Details

Accredited Testing Laboratory

Fire TS Lab - Passive Fire Inspection and Test Services Ltd

Accreditation Number - 1335

1/113 Pavilion Drive, Mangere, Auckland, 2022

New Zealand

Contact e-mail: tests@firelab.co.nz

Issued to:

Firestop Centre Ltd

657 Great South Rd, Penrose, Auckland, 1061

New Zealand

Contact e-mail: info@firestopcentre.co.nz

Manufacturer:

Same as Client/Applicant

3.3 Timeline

Testing date:

01/12/2023

Installation completion date:

30/11/2023

Termination of The Test:

The test was discontinued at 66 minutes.

3.4 Use of the Report

Regulatory information report was issued in addition to full test report PF23095. This provides the minimum information required for regulatory compliance.

The report is valid till 09/08/2028.

This report shall not be reproduced, except in full.

This report details the methods of construction, test conditions and the results obtained when the specific element of construction described herein was tested following the procedure outlined in AS 1530.4. Any significant variation with respect to size, constructional details, loads, stresses, edge or end conditions, other than that allowed under the field of direct application in the relevant test method, is not covered by this report.

Because of the nature of fire resistance testing and the consequent difficulty in quantifying the uncertainty of measurement of fire resistance, it is not possible to provide a stated degree of accuracy of the result.

The test results relate to the specimens of the product in the form in which they were tested. Differences in the composition or thickness of the product may significantly affect the performance during the test and may therefore invalidate the test results. Care should be taken to ensure that any product, which is supplied or used, is fully represented by the specimens, which were tested.

The specimens were supplied by the sponsor and the Laboratory was not involved in any of selection or sampling procedures.

The results of these fire tests may be used to directly assess fire hazard, but it should be recognized that a single test method will not provide a full assessment of fire hazard under all fire conditions.

4. Specimen Description

4.1 Supporting Construction

Separating element		
1.1	Item	90mm timber stud floor with 16mm FR Plasterboard and 19mm structural chipboard
	Aperture	860mm x 860mm
		30mm (nominal) annular gap around duct
		Lined with 1 layers of 13mm FR plasterboard Double timber studs around aperture
	Dimensions	Width / Height (W/H): 1200mm x 1200mm
		Floor Thickness (T): 125mm
		Cavity: 90mm

4.2 Specimen 1 - Duct

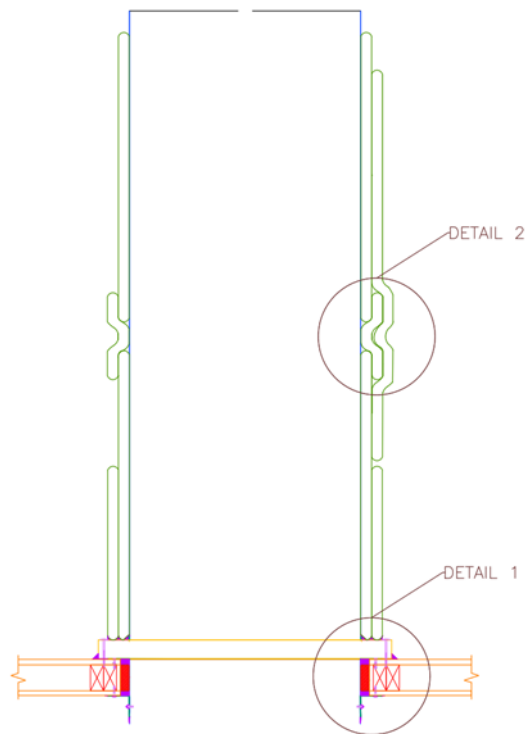

Figure 1a – Duct cross section

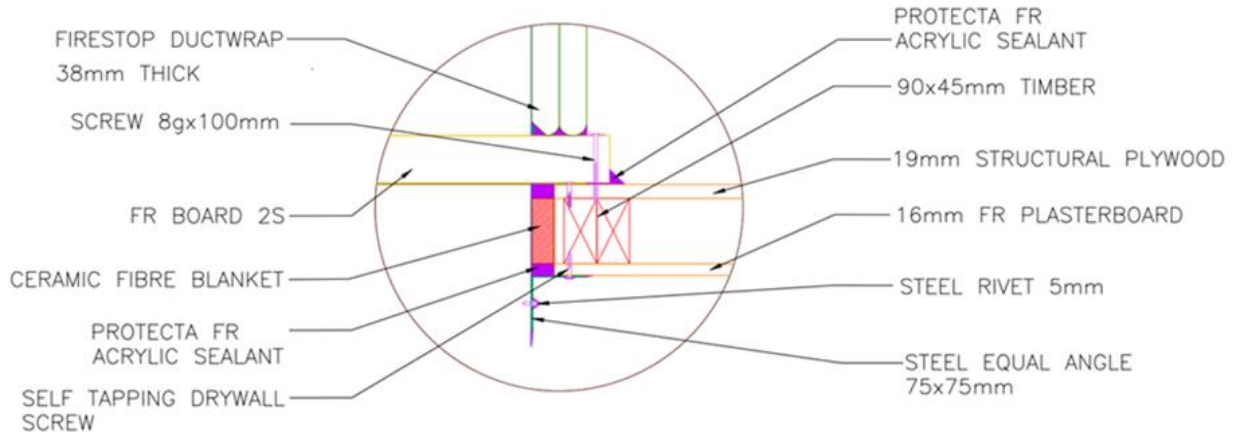

Figure 1b – Detail 1

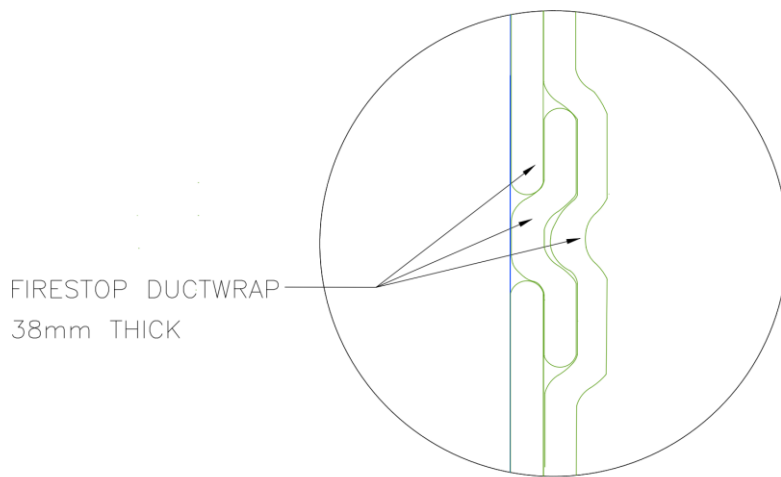

Figure 1c – Detail 2

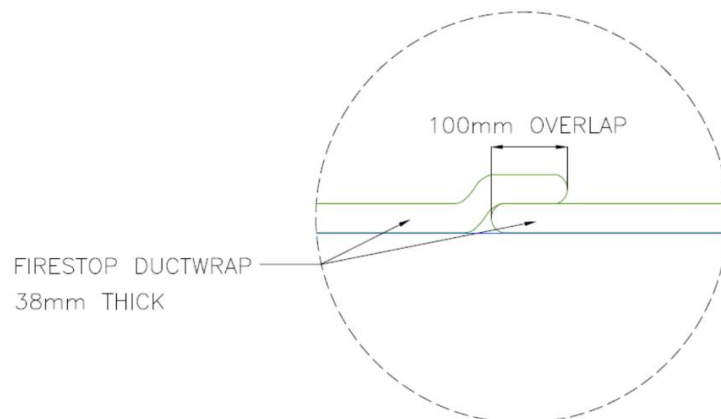

Figure 1d – Detail 3

Specimen		
2.1	Item	Air Duct (as per AS4254.2)
	Measurements	Width / Height / Thickness (W/H/T): 800mm x 800mm x 0.76mm
	Specimen Support	Unistrut structure at 1090mm
	Aperture Size	860mm x 860mm
	Annular Spacing	30mm
	Installation	<p>Asymmetrical – Protrudes 100mm from exposed face, 2175mm from unexposed face.</p> <p>The annular gap between the horizontal separating element and the duct was treated with the strip of Duct Wrap content (ceramic wool) installed in annular gap between duct and separating element, recessed 20mm from both faces. The recess was filled with Acrylic sealant to the nominal depth of 20mm. Steel angles were installed flush with the separating element and fixed to the duct and the separating element. 100mm FR Board collar was installed on the top of the steel angles and fixed to the separating element. All joints were sealed with bead of Acrylic sealant.</p> <p>One layer of the duct wrap was installed around the duct having nominal 100mm overlap for the longitudinal and transverse joints. Longitudinal joints were staggered and located minimum 200mm from the edge of the duct. The first layer of wrap was fixed to the duct with 38mm CD Weld pins at 200mm centres. 63mm CD Weld pins were used to fix the wraps to the duct at overlaps</p> <p>A second layer of wrap was installed using the same overlapping method on top of the first layer, extending 1000mm from the separating element. The second layer of wrap was fixed to the duct with 63mm CD Weld pins at 200mm centres.</p> <p>The duct was tested open on the fire side.</p>

Wrap		
3.1	Item	FIRESTOP Duct Wrap-38 – foil faced ceramic fibre blanket
	Measurements	Thickness / Width / Length (T/W/L): 38mm x 1000mm x 5000mm
	Density	96 kg/m ³
	Installation	<p>Used to wrap the Air duct on unexposed face.</p> <p>1st layer: First length and second length of wrap were 1000mm width. First length was butting up against the board, second layer overlapping the previous by approximately 100mm. A 300mm section of wrap was installed between the end of the second length and the hatch duct wrap</p> <p>2nd Layer: First length of wrap was 1000mm width, butting up against the board. An additional 800mm wide section of wrap was installed on one side of the duct, butt joined to the first length of wrap. The additional layer did not include any transverse joints.</p>

Board		
4.1	Item	Protecta FR Board 2S
	Measurements	Length / Width (L/W): 1200mm x 600mm
	Thickness	Thickness (T): 60mm
	Installation	Cut to 100mm strips, installed around aperture on top of steel bracket.

Sealants / Backing		
5.1	Item	Protecta FR Acrylic Sealant
	Measurements	310mL tube
	Installation	<p>Installed in annular gap between separating element and duct</p> <p>Installed to FR Board joints, between separating element and FR Boards, between FR boards and duct</p>
5.2	Item	FIRESTOP Duct Wrap-38 with foil removed
	Measurements	Thickness / Width (T/W) 38mm x 85mm

	Installation	Strip installed in annular gap between duct and separating element, recessed 20mm from both faces.
--	--------------	--

Fixings		
6.1	Item	Screw 8g x 100mm
	Measurements	100mm
	Installation	Used to fix the FR Board to the plywood around duct at approximately 400mm centres
6.2	Item	Stainless steel Washer
	Measurements	OD: 32mm, ID: 6mm, Thickness 1.5mm
	Installation	Used to fix the FR Board to plywood around duct at approximately 400mm centres
6.3	Item	Firestop Foil Tape
	Measurements	Width: 73mm
	Installation	Used to seal gap formed by overlapped Ductwrap
6.4	Item	GIB Grabber Self Tapping Screws 6mm x 41mm
	Measurements	41mm
	Installation	Used to fix steel angle to plasterboard and plywood at 100mm centres
6.5	Item	Stainless Steel Blind Rivets
	Measurements	10 x 5mm
	Installation	Used to fix the steel angle to duct at 100mm centres
6.6	Item	Steel Equal Angle (nominal)
	Measurements	Width / Height / Thickness: 75mm x 75mm x 1.2mm
	Installation	Used to fix the steel angle to duct
6.7	Item	1 ½ in Duct Pin
	Measurements	Length: 38mm
	Installation	Used to fix single layers of duct wrap to the duct. Pins were attached to the duct using Capacitive Discharge Welder. Pins were located 50mm from the ends of each wrap, and 200mm centres around both the width and the length of the duct.
6.8	Item	2 ½ in Duct Pin

	Measurements	Length: 63mm
	Installation	Used to fix double layers of duct wrap to the duct. Pins were attached to the duct using Capacitive Discharge Welder. Pins were located 50mm from the ends of each wrap, and 200mm centres around both the width and the length of the duct.

4.3 Specimen 2: Hatch

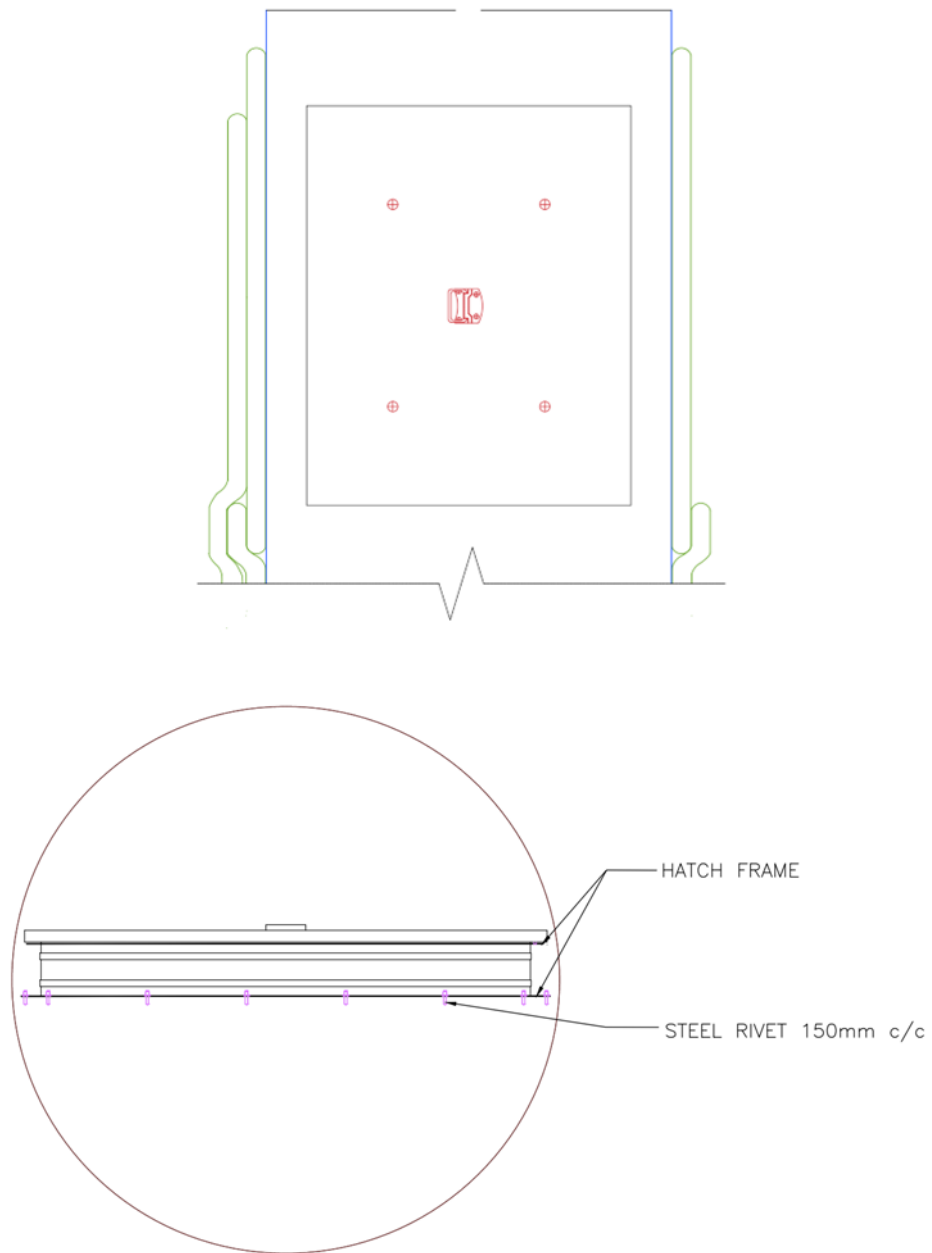

Figure 2 – Hatch installation

Specimen		
2.2	Item	Firestop Duct Hatch 600x450mm
	Measurements	Overall Width / Height / Thickness (W/H/T): 640mm x 790mm x 110mm Opening Width / Height (W/H): 450mm x 600mm
	Specimen Support	Fixed directly to ductwork
	Aperture Size	450mm x 600mm
	Installation	<p>The hatch was fixed to the duct 1075mm from the separating element. The edges of the hatch were no less than 100mm from any edges of the duct.</p> <p>The hatch was fixed to the duct using rivets at approximately 150mm centres around the hatch. The aperture within the hatch was then cut out.</p> <p>One layer of 1000mm duct wrap was installed around the hatch, butting into the hatch webbing. An additional layer of wrap was installed around the perimeter of the hatch, measuring 100mm from all edges of the hatch. The first and second layers of wrap were fixed at 200mm centres using 38mm duct pins and 63mm pins respectively.</p>

Wrap		
3.1	Item	FIRESTOP Duct Wrap-38 – foil faced ceramic fibre blanket
	Measurements	Thickness / Width / Length (T/W/L): 38mm x 1000mm x 5000mm
	Density	96 kg/m ³
	Installation	<p>Used to wrap the Air duct on unexposed face.</p> <p>1st layer: installed around the duct and hatch, butting up against the hatch webbing. Each length of wrap was butt-joined to the previous length.</p> <p>2nd layer: 170mm strips installed into the hatch flanges around the perimeter of the hatch, measuring 100mm from all edges of the duct</p>

Fixings		
6.5	Item	Stainless Steel Blind Rivets
	Measurements	10 x 5mm
	Installation	Used to fix the hatch to duct at 100mm centres
6.7	Item	1 ½ in Duct Pin
	Measurements	Length: 38mm
	Installation	Used to fix single layers of duct wrap to the duct. Pins were attached to the duct using Capacitive Discharge Welder. Pins were located 50mm from the ends of each wrap, and 200mm centres around the both width and length of the duct.
6.8	Item	2 ½ in Duct Pin
	Measurements	Length: 63mm
	Installation	Used to fix double layers of duct wrap to the duct. Pins were attached to the duct using Capacitive Discharge Welder. Pins were located 50mm from the ends of each wrap, and 200mm centres around the both width and length of the duct.

5. Additional temperature measurements

Additional thermocouples were installed to assess the performance of the duct wrap protection at different distances from the floor.

Layers of wrap	From the floor, mm	Maximum temperature rise, deg C			
		30 min	60 min	90 min	120 min
1	1000	150	241	N/A	N/A
	1400	156	242	N/A	N/A
	1900	126	175	N/A	N/A
	1900	87	138	N/A	N/A
2	100	61	165	N/A	N/A
	400	32	119	N/A	N/A
	700	19	107	N/A	N/A
	1600	17	78	N/A	N/A

6. Permissible variations to the tested specimen

A test result obtained for the largest air duct in the range may be applied to all air ducts of the same type (including any aspect ratio), provided the maximum dimensions do not exceed those tested and that the components remain in the same orientation as that tested.